

3-Sided Salt Deflector Kit #60184

FITS 2030Pi and 2130 models

Assembly and Installation Instructions

- Locate all parts as shown in Fig. 1
- Insert #9 Front Deflector Rod into #6 Front Deflector.
- Place #3 Deflector Cam with slot facing to the outside to either end of #9 Deflector Rod.
- Place #4 Deflector Spacer to other end of #9 Deflector Rod
- Take Front Deflector Assembly and insert each end of #9 Deflector Rod into #1 Deflector Corners
- Tighten #7 Pan Head Philips Screw in #1 Deflector Corner, completing the Deflector assembly.

Note: All Deflector lower edges taper to the inside of the assembly.

Installation on spreader

You will need to drill a 1/4" hole inside the hopper in the 4 cross marked locations as shown in Fig. 2. Slide deflector assembly from front to back of the spreader. Insert 1/4-20 x 1" Hex Head bolt #13 into the bolt holes in arms #10 and #11, then slide plastic spacer # 14 over the bolt, then push the bolt into the drilled holes in the hopper. Next place the flat plastic washer #15 over the bolt and secure with 1/4" Locknut. Repeat on other positions, then tighten securely.

Fig. 1

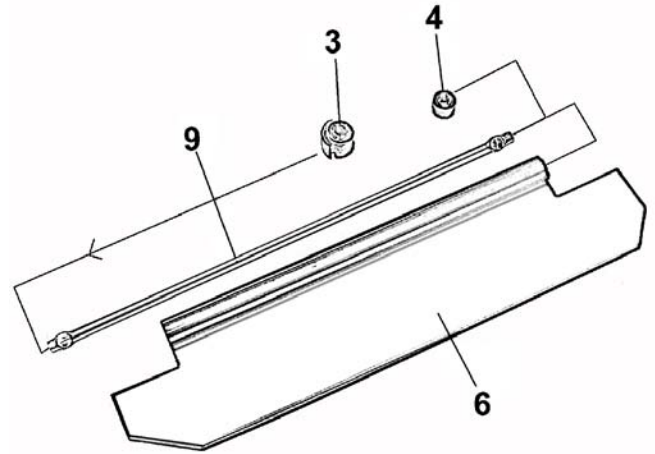

Fully assembled

Hole positions

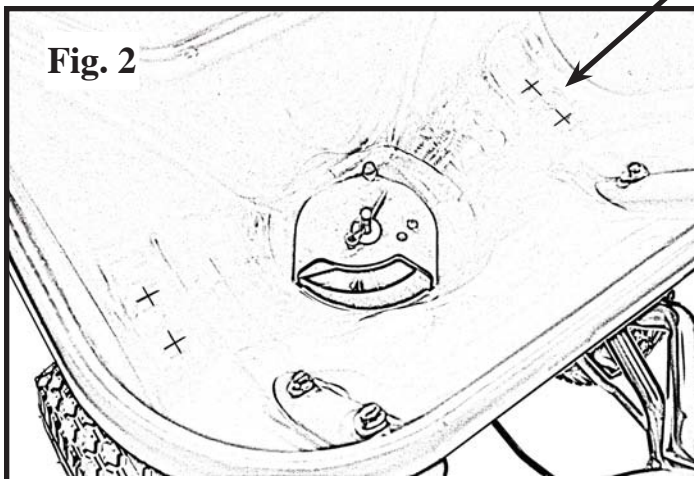
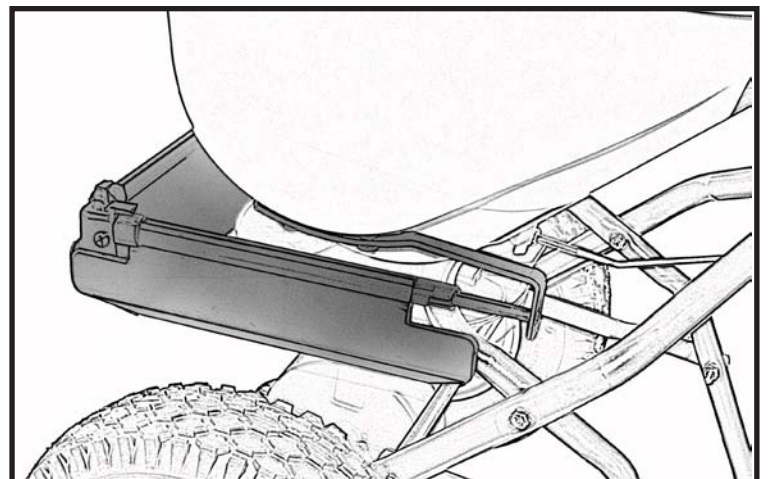
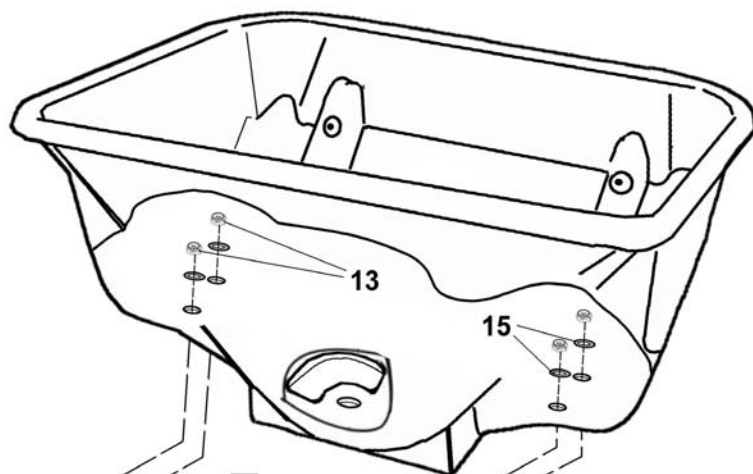
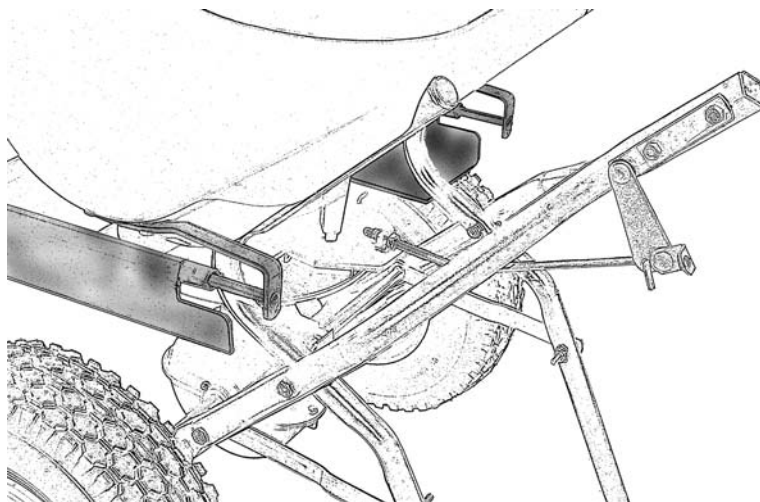

Fig. 2



60184 Deflector Parts List

Key #	Part#	Description
1	12335	Deflector Corner
2	12336	Deflector Stop
3	12337	Deflector Cam
4	12338	Deflector Spacer
5	12339	Side Deflector
6	12231	Front Deflector
7	31124	#10 x 5/8 Type A Phillips Head Screw
8	42284	Side Deflector Bracket & Rod Assy
9	42286	Front Deflector Rod
10	60162	Left Deflector Assembly
11	60163	Right Deflector Assembly
12	36210	¼-20 x 1" HHMS Stainless Steel Bolt
13	36300	¼-20 Lock Nut Stainless Steel
14	12243	Gauge Spacer
15	12140	Washer



OPERATION

To operate your deflectors from the closed/down position, lift the deflector (#5 or 6) to allow full spread width spreading.

To stop spreading to one or more sides, push the deflector (#5 or 6) down.

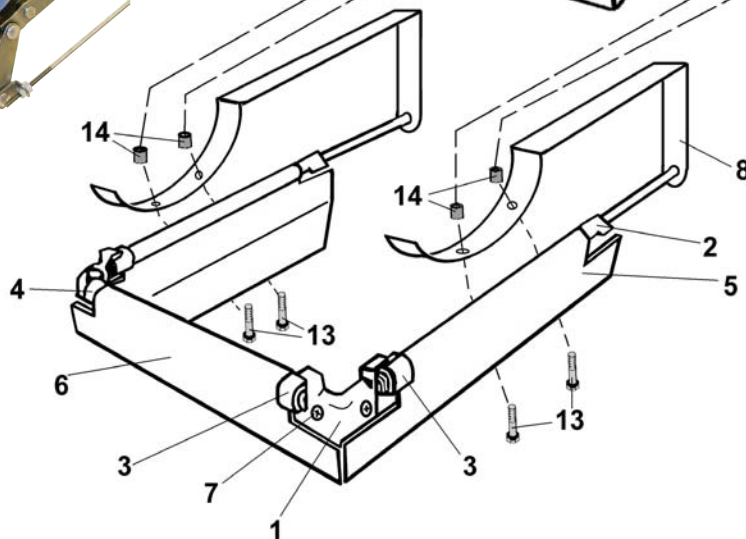

WARRANTY

This product is guaranteed to be free of defects in original workmanship and materials for a period of 90-days from the date of sale to the original user. If any defect develops during this period the manufacturer will repair or replace this product at no charge provided the defect is not the result of mishandling or tampering and that this product is received at the factory with shipping charges paid. Proof of purchase must be included. For quicker service you may call 574-848-7491 and describe the nature of the defect and we will send repair parts to you. This warranty does not cover labor charges. Due to the corrosive nature of most fertilizers and ice melters, the manufacturer makes no warranty or guarantee against corrosion failure on models with plated steel or painted steel frames. Clean and dry your spreader well after each use.